



GSA-50

Precision planetary servogearboxes

for general automation

The first catalog for engineers

Background

When an engineer needs to select a precision planetary gearbox from any major supplier, he finds himself in the following dilemma:

If the supplier is from Europe, he will have to deal with the following hurdles:

- Intermittent duty cycle is loosely defined as 1000 cycles per hour, with acceleration time, deceleration time, and dwell time undefined.
- There is no data for less than 1000 cycles per hour, and for more cycles per hour, the engineer must refer to generic tables for correction factors.
- Continuous duty cycle (ED=100%) is also either undefined, and whatever data relates to it is insufficient.
- Axial and radial capacities are vastly exaggerated for marketing purposes. Sometimes, they even don't respect the bearings static safety factors.
- Should an extended service life for the gear be required, there is no data on how to obtain it.

Additionally, if the supplier is from Asia, he might also have to deal with the following 3 extra issues:

- **Vastly overstated torque values that have little basis on reality.** Taking advantage of most customers' lack of knowledge (as they know most customers lack deep knowledge when it comes to mechanical transmissions), the listed values are hand picked from situations unlikely to resemble actual use, for purely marketing based reasons.
- **10000 hours actual design life** hidden in small print footnotes, in an attempt to justify the exaggerated torque values.
- **Misused or redefined terminology** that is clearly defined by ISO and DIN western standards. For example "**rated torque**" often means "**acceleration torque**".

GS gearboxes: The professionals' choice

On the other hand, GE gearboxes present the following advantages:

- **Quick and reliable gearbox selection.** There is explicit data for every number of cycles per hour, from 60 to 12000, allowing the engineer to quickly and reliably select the needed gearbox. There is no wasted time checking additional tables or applying additional safety factors. In over 80% of the cases, there is no need to resort to specialized software to make the gearbox selection.
- **Longer service life.** For machines that require very long service life, such as machine tools, Servotak's listed torque values refer to up to 100000 hours design life for continuous duty cycles, and 40000 hours design life for intermittent duty cycles, doubling the western market standards and quadrupling the Asian ones. This is thanks to its use of high quality alloy steels used for the gears, and to the high quality tooth profile. Additionally Servotak employs case hardened gears which goes deep into the steel, unlike other manufacturers' nitrided gears that, while cheaper, only hardens a thin layer that wears out much faster. This allows us to offer higher safety on both tooth flanks and tooth roots, further extended service life.
- **100000 hour bearing design life.** In addition to providing the static radial load capacity, Servotak provides a graph plotting radial capacity vs speed, with design life up to 100000 hours. The gears' needle bearings are even longer lasting, with a design life of 120000 hours.

More competitive machines thanks to GSA gearboxes



High performance for every machine axis

GSA gearboxes high value for money makes it the ideal solution for OEMs that require very high reliability that is competitively priced. They are designed for both continuous and intermittent duty cycles, and are suitable for a wide range of applications, from general automation to multi-axis machine tools and robotics.

GSA gearboxes are the natural evolution of the GE-Economy series and present the following improvements:

- Longer service life, with up to 100000 hours.
- High power transmission capacity.
- Smoother operation.

Highlights

Transmission ratio	3 to 100
Max. Torque	60 Nm
Backlash	<8' to <12' (arcmin)
Efficiency	97%
Service life up to	100000 hours
Max. radial shaft load	930 N
Lifetime lubrication and maintenance-free.	
For every mounting position.	
DIN-6885-1 output shaft with key, with DIN-332-2 hole.	

For every mounting position

GSA gearboxes can be mounted in any position. However, if mounted horizontally, they can be lubricated with a special grease that increases torque transmission capabilities, offers an even smoother operation, and extends service life.

High value for money

GSA offers high quality at a competitive price. This makes it ideal for general automation applications that require high reliability but only moderate precession.

Simple motor mounting

It's modular design allows for input flanges to be designed for every possible motor. Installers will find that motor mounting is simple, safe, and error-free. A shrink disk with sideways tightening screws offers a more secure motor shaft connection.

Rack & pinion linear systems with GSA-050 gearboxes

More competitive and reliable machines

Servotak's rack-pinion-gearbox systems are the ideal solution for OEMs requiring a highly reliable product that maintains a competitive price. They are used in machine tool and general automation machines that don't require the highest precision. For these cases, Servotak offers linear systems with moderate precision and feed forces.

With racks with modules ranging from 0,5 to 6 and GSA gearboxes, allow for multi-ton loads to be displaced with medium precision, quiet operation, and high reliability.

Servotak offers five rack and pinion series, Basic, Classic, Professional, Advanced and Master. with 15 modules for straight teeth systems, and 12 for helical teeth systems, it covers every use case. For higher precisions and heavier loads, SG gearboxes complete the set, and allow for feed forces of up to 400000 N.

The safest racks

Servotak's Basic, Advanced and Master racks are taller than market standard ranks. This extra mass grants them higher rigidity and allows them to better absorb overloads, offer vibration free operation, and as a result, deliver better finishes when used in machine tools. Their 2-row fixing hole arrangement offers the most secure operation in emergency situations.



Precision and Feed Force

5 rack series combined with GS gearboxes offer moderate precision and feed force at a high value per money, making them ideal for use cases such as general automation, machine tool and robotics,

Smooth operation

Servotak linear systems are known for their remarkably smooth operation thanks to an optimized tooth profile on all gears, and a perfect balance on all the systems' parts.

Maximum Reliability

Our engineers can offer complete rack-pinion-gearbox systems that are hand tuned for your specific application, and so can offer the highest reliability for even the most stringent requirements.

GSA-050

The following technical specifications resulted from exhaustive calculations according to DIN, ISO and AGMA norms, years of research and experience, and Servotak's traditional reliability-first approach. This is why our gearboxes can offer the highest reliability and the a design life of up to 100000 hours, way above the norm.

Ideal for S5 intermittent duty

Instead of offering a single output torque value, and then asking engineers to apply service factors depending on cycles per hour, we present a tabulated list of output torques at most common cycle rate values.

The listed values for S5 intermittent duty assume general purpose applications. Specific duty cycles might allow for higher output torques. Should you think that your specific application's details don't fit our assumptions, please contact our engineers for a through study. We also offer an online tool to calculate the RMS average torque for complex cycles at https://servotak.eu/tools/duty_cycle_calculator.

A word about S1 continuous duty

Over 90% of the commonly available planetary gearboxes are designed for intermittent duty cycles. They are not designed for S1 continuous duty cycles. The reason being that one of the main advantages of planetary gearboxes is their compact design. While this offers great space savings, it also reduces the outer surface needed to radiate heat, and in S1 cycles, this reduces the amount of power they can transmit. Should you require such duty cycles out of a planetary gearbox, there are some things you need to remember:

- Ensure there is good airflow around the gearbox. Transmissible torque can be further increased by using active cooling methods on the gearbox, such as forced cooling.
- The gearbox mounting surface can also act as a heat sink. If possible, ensure it extends around the gearbox, is exposed, and receives good airflow.
- Brushless motors generate considerable amount of heat, and thus further reduce the gearbox's torque transmission capacity. Employ motors with built in cooling fins and cooling fans.
- Grease lubrication is a poor match for S1 cycles, as it does a poor job at cooling gears and bearings.
-
- High input speeds further increase generated heat and thus further reduce torque transmission capacity.

Our engineers will be more than happy to advise you on the different caveats of gearboxes en S1 cycles.

Technical data for S5 intermittent service

GSA-050-M1 (1 stage)		Ratio			
		3	5	7	10
Max. Acceleration output torque for a 40000 hour design life and S5 intermittent duty cycles, T_{2max} (Nm) S5 intermittent duty cycle Duty cycle ED<60%, Cycle duration t_{cycle} <20 min Average cycle speed $\leq n_{1TH}$ Maximum cycle speed $\leq n_{1max}$ As per DIN-3990 and ISO-6336	60 cycles/hour	66	58	58	49
	120 cycles/hour	61	52	52	48
	300 cycles/hour	55	48	48	42
	600 cycles/hour	51	45	45	41
	1500 cycles/hour	46	41	41	40
	3000 cycles/hour	42	40	40	38
	6000 cycles/hour	37	39	39	37
	9000 cycles/hour	35	38	38	36
	12000 cycles/hour	34	37	37	34
RMS average torque for 40000 hours design life and a typical S5 intermittent duty cycle, T_{2TH} (Nm) S5 intermittent duty cycle Duty cycle ED<60%, Cycle duration t_{cycle} <20 min Average cycle speed n_{1TH} As per DIN-3990 and ISO-6336	60 cycles/hour	33	29	28	25
	120 cycles/hour	30	26	26	24
	300 cycles/hour	27	24	25	21
	600 cycles/hour	25	23	23	20
	1500 cycles/hour	23	21	22	20
	3000 cycles/hour	21	20	22	19
	6000 cycles/hour	19	20	21	19
	9000 cycles/hour	17	19	20	18
12000 cycles/hour	17	19	20	17	
Emergency Stop Torque, T_{2E} (Nm) (up to 1000 times during product lifetime)		65	75	75	75
Maximum input speed for S5 intermittent duty cycle operation, n_{1max} (rpm)		3800	5000	6000	6000
Average input speed for S5 intermittent service, n_{1TH} (rpm) Values for 20°C ambient temperature (For higher temperatures, reduce input speed).		2500	3300	3500	3500

Technical data for S1 continuous service

GSA-050-M1 (1 stage)		Ratio			
		3	5	7	10
Maximum start-up output torque for S1 continuous duty, T_{2max} (Nm) S1 continuous duty Duty Cycle ED>60% Cycle Duration $t_{cycle}>20$ min Average cycle speed $\leq n_{1TH}$ Maximum cycle speed $\leq n_{1max}$ As per DIN-3990	5000 hours	67	51	44	42
	10000 hours	58	46	40	38
	25000 hours	46	42	36	33
	50000 hours	38	34	33	30
	100000 hours	35	31	31	27
Average output torque for S1 continuous duty, T_{2TH} (Nm) S1 continuous duty Duty Cycle ED>60% Cycle Duration $t_{cycle}>20$ min Average cycle speed n_{1TH} Maximum cycle speed $\leq n_{1max}$ As per DIN-3990	5000 hours	41	31	27	26
	10000 hours	35	28	24	23
	25000 hours	28	25	22	20
	50000 hours	23	21	20	18
	100000 hours	21	21	19	17
Emergency Stop Torque, T_{2E} (Nm) (up to 1000 times during product lifetime)		70	80	80	80
Maximum input speed for S1 continuous duty, n_{1max} (rpm) Only for short periods		2500	3500	3500	3500
Maximum rated input speed for S1 continuous duty, n_{1TH} (rpm) Assumes ambient temperature of 20°C (if >20°C, lower the input speed) This speed can be maintained for the whole cycle		2200	3000	3000	3000

General technical data

GSA-050-M1 (1 stage)		Ratio			
		3	5	7	10
Torsional Backlash $\Delta\phi$ (arcmin)		<10	<10	<10	<12
Torsional Stiffness C (Nm / arcmin)		4	3,3	3.3	2,8
Efficiency η (%)		97%	97%	97%	97%
Inertia (kg·cm ²) for motor output shaft of diameter	ø11mm	0,13	0,07	0,06	0,06
	ø14mm	0,37	0,31	0,30	0,30
Environmental conditions Outside of this range, please inquire.		-15°C to 40°C			
Maximum allowable housing temperature, T (°C)		90°C			
Protection degree		IP 64			
Noise level Unloaded, at $n_1=3000$ rpm, from a 1m distance		<69 dB(A)			
Lubrication		Lifetime grease lubrication			
Direction of rotation		Same as motor			
Weight (kg)		1,45			

Technical data for S5 intermittent service

GSA-050-M2 (2 stages)		Ratio							
		15	21	25	30	35	50	70	100
Max. Acceleration output torque for a 40000 hour design life and S5 intermittent duty cycles, T_{2max} (Nm) S5 intermittent duty cycle Duty cycle ED<60%, Cycle duration $t_{cycle}<20$ min Average cycle speed $\leq n_{1TH}$ Maximum cycle speed $\leq n_{1max}$ As per DIN-3990 and ISO-6336	60 cycles/hour	66	66	58	66	58	58	58	49
	120 cycles/hour	61	61	52	61	52	52	52	48
	300 cycles/hour	55	55	48	55	48	48	48	42
	600 cycles/hour	51	51	45	51	45	45	45	41
	1500 cycles/hour	46	46	41	46	41	41	41	40
	3000 cycles/hour	42	42	40	42	40	40	40	38
	6000 cycles/hour	37	37	39	37	39	39	39	37
	9000 cycles/hour	35	35	38	35	38	38	38	36
12000 cycles/hour	34	34	37	34	37	37	37	34	
RMS average torque for 40000 hours design life and a typical S5 intermittent duty cycle, T_{2TH} (Nm) S5 intermittent duty cycle Duty cycle ED<60%, Cycle duration $t_{cycle}<20$ min Average cycle speed n_{1TH} As per DIN-3990 and ISO-6336	60 cycles/hour	33	33	29	33	29	29	28	25
	120 cycles/hour	30	30	26	30	26	26	26	24
	300 cycles/hour	27	27	24	27	24	24	25	21
	600 cycles/hour	25	25	23	25	23	23	23	20
	1500 cycles/hour	23	23	21	23	21	21	22	20
	3000 cycles/hour	21	21	20	21	20	20	22	19
	6000 cycles/hour	19	19	20	19	20	20	21	19
	9000 cycles/hour	17	17	19	17	19	19	20	18
12000 cycles/hour	17	17	19	17	19	19	20	17	
Emergency Stop Torque, T_{2E} (Nm) (up to 1000 times during product lifetime)		65	65	75	65	75	75	80	80
Maximum input speed for S5 intermittent duty cycle operation, n_{1max} (rpm)		3800	3800	5000	3800	5000	5000	6000	6000
Average input speed for S5 intermittent service, n_{1TH} (rpm) Values for 20°C ambient temperature (For higher temperatures, reduce input speed).		2500	2500	3300	2500	3300	3300	3500	3500

Technical data for S1 continuous service

GSA-050-M2 (2 stages)		Ratio							
		15	21	25	30	35	50	70	100
Maximum start-up output torque for S1 continuous duty, T_{2max} (Nm) S1 continuous duty Duty Cycle ED>60% Cycle Duration $t_{cycle}>20$ min Average cycle speed $\leq n_{1TH}$ Maximum cycle speed $\leq n_{1max}$ As per DIN-3990	5000 hours	67	67	51	67	51	51	44	42
	10000 hours	58	58	46	58	46	46	40	38
	25000 hours	46	46	42	46	42	42	36	33
	50000 hours	38	38	34	38	34	34	33	30
	100000 hours	35	35	31	35	31	31	31	27
Average output torque for S1 continuous duty, T_{2TH} (Nm) S1 continuous duty Duty Cycle ED>60% Cycle Duration $t_{cycle}>20$ min Average cycle speed n_{1TH} Maximum cycle speed $\leq n_{1max}$ As per DIN-3990	5000 hours	41	41	31	41	31	31	27	26
	10000 hours	35	35	28	35	28	28	24	23
	25000 hours	28	28	25	28	25	25	22	20
	50000 hours	23	23	21	23	21	21	20	18
	100000 hours	21	21	21	21	21	21	19	17
Emergency Stop Torque, T_{2E} (Nm) (up to 1000 times during product lifetime)		70	70	80	70	80	80	80	80
Maximum input speed for S1 continuous duty, n_{1max} (rpm) Only for short periods		2500	2500	3500	2500	3500	3500	3500	3500
Maximum rated input speed for S1 continuous duty, n_{1TH} (rpm) Assumes ambient temperature of 20°C (if >20°C, lower the input speed) This speed can be maintained for the whole cycle		2200	2200	3000	2200	3000	3000	3000	3000

General technical data

GSA-050-M2 (2 stages)		Ratio							
		15	21	25	30	35	50	70	100
Torsional Backlash $\Delta\phi$ (arcmin)		<15	<15	<15	<15	<15	<15	<15	<15
Torsional Stiffness C (Nm / arcmin)		4	4	4	4	4	3,3	3,3	2,8
Efficiency η (%)		95%	95%	95%	95%	95%	95%	95%	95%
Inertia (kg·cm ²) for motor output shaft of diameter	ø11mm	0,10	0,07	0,07	0,13	0,06	0,06	0,06	0,06
	ø14mm	0,37	0,31	0,31	0,37	0,30	0,30	0,29	0,30
Environmental conditions Outside of this range, please inquire.		-15°C to 40°C							
Maximum allowable housing temperature, T (°C)		90°C							
Protection degree		IP 64							
Noise level, Unloaded, at $n_1=3000$ rpm, from a 1m distance		<69 dB(A)							
Lubrication		Lifetime grease lubrication							
Direction of rotation		Same as motor							
Weight (kg)		1.95							

Bearings

Planet gears in GSA-050 gearboxes turn over needle bearing with a design life of over 120000 hours. The input shaft is supported by a stiff, sealed, and self lubricating ball bearing, with a design life that is greater than 120000 hours. The output shaft uses stiff self lubricating, sealed and self lubricating ball bearings with protection covers on both sides, that allow operation at high speeds, a high load capacity, and while keeping the gearbox leak-proof

Bearing service life depends mostly on output speed and axial load. For this calculation, radial load is assumed to be in the middle of the output shaft. Other factors, such as lubricant type, normally occurring impurities in the lubricant, operating temperature, etc. have been considered. Refer to the following curves. For specific applications, contact our engineering team.

Permissible shaft loads

Based on nominal bearing lifetime (L_{nh} as per ISO 281)

	Maximum Value	10000 hours	20000 hours	30000 hours	40000 hours
F _{2R} (N) Allowable radial force (Applied to the middle of the output shaft and n ₂ =100 rpm)	1500	960	760	670	610
F _{2A} (N) Allowable axial force n ₂ =100rpm (For both push and pull)	3100	2500	1900	1550	1400
F _{2R} = F _{2A} (N) simultaneously. For other complex cases, please inquire.	1500	930	720	615	550

Bearing design life

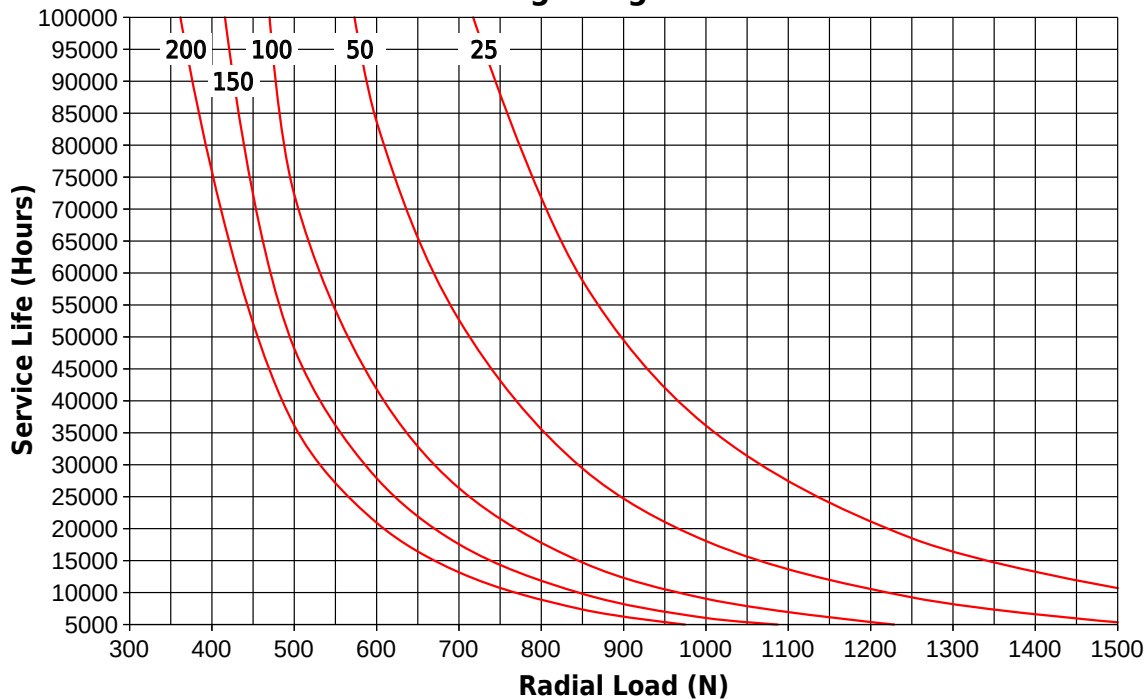

Bearing design life based on radial load (N) and output speed (rpm)
Standard calculation as per DIN ISO 281

Dimensions

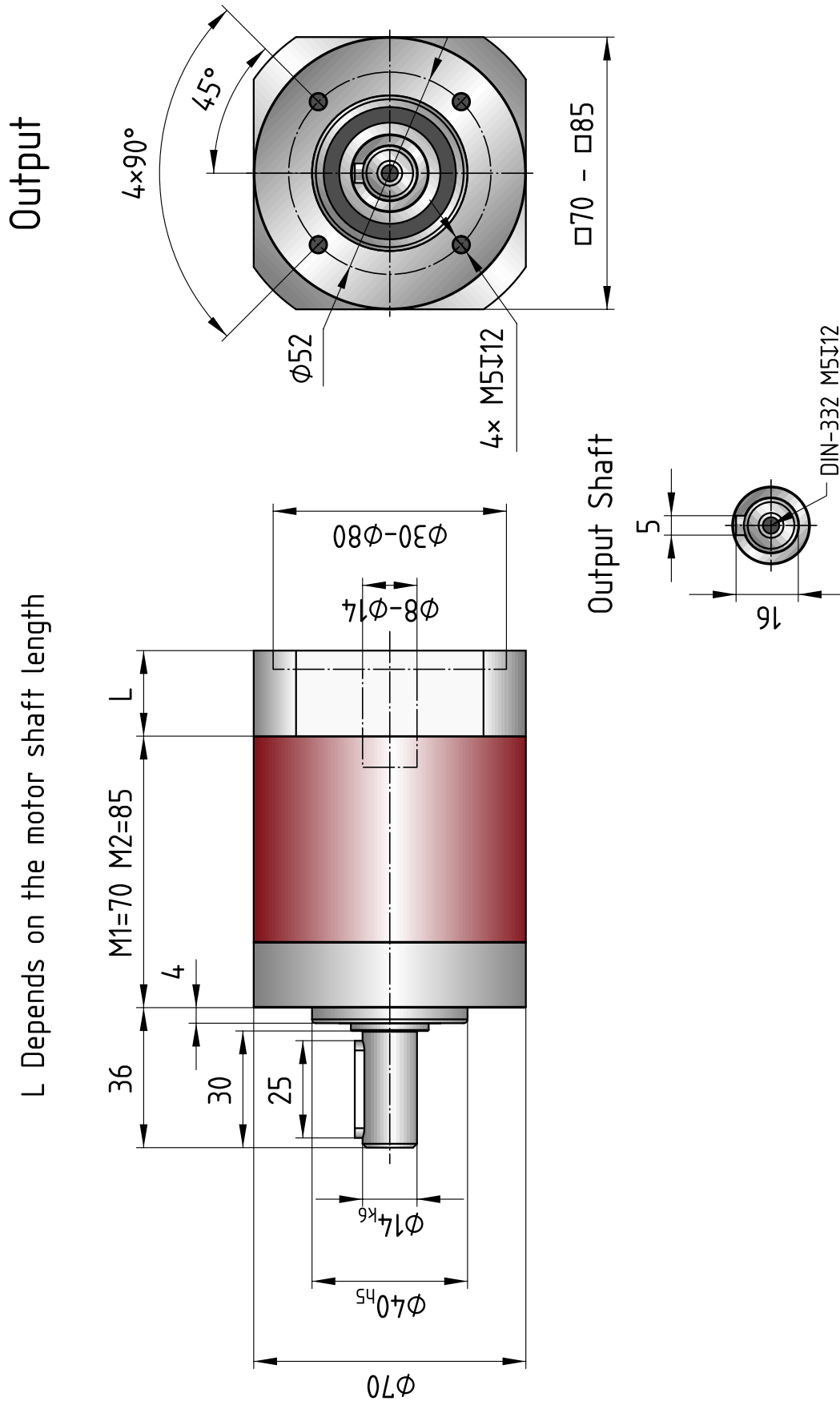

All dimensions are in mm. Dimensions suitable for most motor models. For outliers, please inquire.
All values subject to change due to technical improvements without further notice.

Options

Special paint for corrosive environments

GSA-050 gearboxes can be delivered coated with a special corrosion-resistant paint. It's composed of a 2K epoxy-polyamide resin based primer with zinc phosphates, plus a high quality high wear resistance coat of pain. It offers excellent protection against corrosion in both industrial environments and in exposed natural ones, such as in contact with sea waters, even on critical surfaces such as aluminum. It offers high chemical and abrasion resistance.



- Thick 2K epoxy-polyamide resin based primer
- RAL-9005 black paint finish.
- Treatment might be applied to the the whole housing, or only to the exposed steel parts

Ready for explosive atmospheres (ATEX)

GSA-050 gearboxes can be ordered compliant with the requirements of directive 2014/34/UE relating to equipment and protective systems intended for use in potentially explosive atmospheres.



Ratings

- EX II 3G ck T3
- EX II 3D ck T3
- EX II 3GD ck T3
- EX II 2G ck T3
- EX II 2D ck T3
- EX II 2GD ck T3

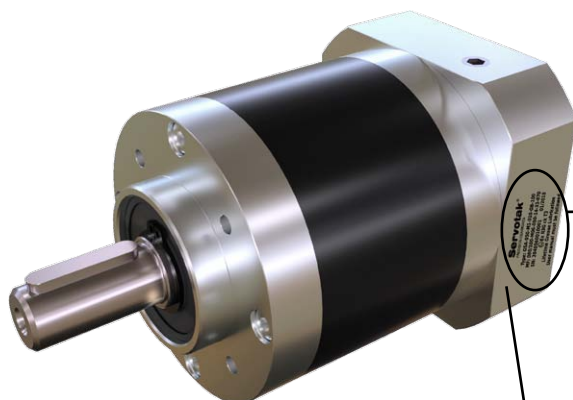

Atex labeling

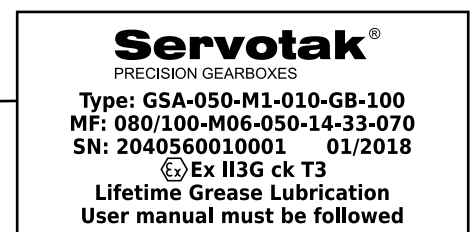

Available with input flanges for servomotors and for asynchronous IEC motors