

SGS-080

Precision planetary servogearboxes

Outstanding features

- Output shaft with tapered roller bearings
- Output torque: 81 to 185 Nm
- Synthetic oil lubrication
- Ultra low friction

Technical data for S5 intermittent service

SGS-080-M1 (1 stage)		Ratio			
		3	5	7	10
<p>Max. Acceleration output torque for 40000 hour design life in S5 intermittent duty cycles, T_{2max} (Nm)</p> <p>S5 intermittent duty cycle Duty cycle ED<60%, Cycle duration t_{cycle}<20 min Average cycle speed $\leq n_{1TH}$ Maximum cycle speed $\leq n_{1max}$ As per DIN-3990 and ISO-6336</p>	60 cycles/hour	185	153	132	137
	120 cycles/hour	149	141	118	123
	300 cycles/hour	126	126	102	116
	600 cycles/hour	124	125	96	106
	1500 cycles/hour	127	123	96	105
	3000 cycles/hour	114	114	94	103
	6000 cycles/hour	99	103	93	100
	9000 cycles/hour	82	93	89	92
	12000 cycles/hour	81	89	84	88
<p>RMS average torque for 40000 hour design life in a typical S5 duty cycle, T_{2TH} (Nm)</p> <p>S5 intermittent duty cycle Duty cycle ED<60%, Cycle duration t_{cycle}<20 min Average cycle speed n_{1TH} Maximum cycle speed $\leq n_{1max}$ As per DIN-3990 and ISO-6336</p>	60 cycles/hour	93	76	66	69
	120 cycles/hour	75	70	59	61
	300 cycles/hour	63	63	51	58
	600 cycles/hour	62	63	48	53
	1500 cycles/hour	64	62	48	53
	3000 cycles/hour	57	57	47	51
	6000 cycles/hour	50	51	47	50
	9000 cycles/hour	41	47	44	46
12000 cycles/hour	40	45	42	44	
<p>Emergency Stop Torque, T_{2E} (Nm)</p> <p>Up to 1000 times during product lifetime</p>		218	264	230	230
<p>Maximum input speed for S5 intermittent duty cycle operation, n_{1max} (rpm)</p>		6000	7000	7000	7000
<p>Average input speed for S5 intermittent service, n_{1TH} (rpm)</p> <p>Values for 20°C ambient temperature (For higher temperatures, reduce input speed).</p>		2500	3200	3500	4000

Technical data for S1 continuous service

SGS-080-M1 (1 stage)		Ratio			
		3	5	7	10
Maximum start-up torque for S1 continuous duty, T_{2max} (Nm) S1 continuous duty Duty Cycle ED>60% Cycle Duration $t_{cycle}>20$ min Average cycle speed $\leq n_{1TH}$ Maximum cycle speed $\leq n_{1max}$ As per DIN-3990	5000 hours	263	149	193	199
	10000 hours	224	143	129	164
	25000 hours	167	134	129	152
	50000 hours	147	118	109	144
	100000 hours	142	118	109	140
S1 continuous duty output torque, T_{2TH} (Nm) S1 continuous duty Duty Cycle ED>60% Cycle Duration $t_{cycle}>20$ min Average cycle speed n_{1TH} Maximum cycle speed $\leq n_{1max}$ As per DIN-3990	5000 hours	175	99	128	133
	10000 hours	149	95	86	109
	25000 hours	111	89	86	102
	50000 hours	98	79	73	96
	100000 hours	95	79	73	93
Emergency Stop Torque T_{2E} (Nm) up to 1000 times during product lifetime		218	264	230	230
Maximum input speed for S1 continuous duty, n_{1max} (rpm) Only for short periods		3500	3500	4000	4000
Maximum rated input speed for S1 continuous duty, n_{1TH} (rpm) Assumes ambient temperature of 20°C (if >20°C, lower the input speed) This speed can be maintained for the whole cycle		2500	3300	3500	3700

General technical data

SGS-080-M1 (1 stage)		Ratio			
		3	5	7	10
Standard Torsional Backlash $\Delta\phi$ (arcmin)		<8	<8	<8	<10
Torsional Stiffness C (Nm / arcmin)		10	11	11	10
Efficiency η (%)		97	97	97	97
Inertia due to input shaft ϕ (kg·cm ²)	$\phi 19$ mm	0.871	0.682	0.606	0.576
	$\phi 24$ mm	1.388	1.127	1.044	1.014
Environmental conditions Values outside of this range available upon request		-15°C to 40°C			
Protection degree		IP 64			
Noise level, Unloaded, at $n_1=3000$ rpm, from a 1m distance		<69 dB(A)			
Lubrication		Synthetic Oil			
Direction of rotation		Same as motor			
Weight (kg)		4.1			
Max. allowable housing temperature T (°C)		90 °C			

Technical data for S5 intermittent service

SGS-080-M2 (2 stages)		Ratio					
		15	25	30	50	70	100
Max. Acceleration output torque for 40000 hour design life in S5 intermittent duty cycles, T_{2max} (Nm) S5 intermittent duty cycle Duty cycle ED<60%, Cycle duration $t_{cycle}<20$ min Average cycle speed $\leq n_{1TH}$ Maximum cycle speed $\leq n_{1max}$ As per DIN-3990 and ISO-6336	60 cycles/hour	185	153	185	153	132	137
	120 cycles/hour	149	141	149	141	118	123
	300 cycles/hour	126	126	126	126	102	116
	600 cycles/hour	124	125	124	125	96	106
	1500 cycles/hour	127	123	127	123	96	105
	3000 cycles/hour	114	114	114	114	94	103
	6000 cycles/hour	99	103	99	103	93	100
	9000 cycles/hour	82	93	82	93	89	92
	12000 cycles/hour	81	89	81	89	84	88
RMS average torque for 40000 hour design life in a typical S5 duty cycle, T_{2TH} (Nm) S5 intermittent duty cycle Duty cycle ED<60%, Cycle duration $t_{cycle}<20$ min Average cycle speed n_{1TH} Maximum cycle speed $\leq n_{1max}$ As per DIN-3990 and ISO-6336	60 cycles/hour	93	76	93	76	66	69
	120 cycles/hour	75	70	75	70	59	61
	300 cycles/hour	63	63	63	63	51	58
	600 cycles/hour	62	63	62	63	48	53
	1500 cycles/hour	64	62	64	62	48	53
	3000 cycles/hour	57	57	57	57	47	51
	6000 cycles/hour	50	51	50	51	47	50
	9000 cycles/hour	41	47	41	47	44	46
12000 cycles/hour	40	45	40	45	42	44	
Emergency Stop Torque, T_{2E} (Nm) Up to 1000 times during product lifetime		218	264	218	264	230	230
Maximum input speed for S5 intermittent duty cycle operation, n_{1max} (rpm)		6000	7000	6000	7000	7000	7000
Average input speed for S5 intermittent service, n_{1TH} (rpm) Values for 20°C ambient temperature (For higher temperatures, reduce input speed).		3000	4000	3000	4000	4000	4000

Technical data for S1 continuous service

SGS-080-M2 (2 stages)		Ratio					
		15	25	30	50	70	100
Maximum start-up torque for S1 continuous duty, T_{2max} (Nm) S1 continuous duty Duty Cycle ED>60% Cycle Duration $t_{cycle}>20$ min Average cycle speed $\leq n_{1TH}$ Maximum cycle speed $\leq n_{1max}$ As per DIN-3990	5000 hours	263	149	263	149	193	199
	10000 hours	224	143	224	143	129	164
	25000 hours	167	134	167	134	129	152
	50000 hours	147	118	147	118	109	144
	100000 hours	142	118	142	118	109	140
S1 continuous duty output torque, T_{2TH} (Nm) S1 continuous duty Duty Cycle ED>60% Cycle Duration $t_{cycle}>20$ min Average cycle speed n_{1TH} Maximum cycle speed $\leq n_{1max}$ As per DIN-3990	5000 hours	175	99	175	99	128	133
	10000 hours	149	95	149	95	86	109
	25000 hours	111	89	111	89	86	102
	50000 hours	98	79	98	79	73	96
	100000 hours	95	79	95	79	73	93
Emergency Stop Torque T_{2E} (Nm) up to 1000 times during product lifetime		218	264	218	264	230	230
Maximum input speed for S1 continuous duty, n_{1max} (rpm) Only for short periods		3500	4000	3500	4000	4000	4000
Maximum rated input speed for S1 continuous duty, n_{1TH} (rpm) Assumes ambient temperature of 20°C (if >20°C, lower the input speed) This speed can be maintained for the whole cycle		2500	3300	2500	3300	3500	3500

General technical data

SGS-080-M2 (2 stages)		Ratio					
		15	25	30	50	70	100
Standard Torsional Backlash $\Delta\phi$ (arcmin)		<12	<15	<12	<15	<15	<15
Torsional Stiffness C (Nm / arcmin)		10	11	10	11	11	10
Efficiency η (%)		94	94	94	94	94	94
Inertia due to input shaft ϕ (kg·cm ²)	$\phi 19$ mm	0.857	0.682	0.830	0.655	0.605	0.576
	$\phi 24$ mm	1.303	1.127	1.268	1.093	1.043	1.014
Environmental conditions Values outside of this range available upon request		-15°C to 40°C					
Protection degree		IP 64					
Noise level, Unloaded, at $n_1=3000$ rpm, from a 1m distance		<69 dB(A)					
Lubrication		Synthetic Oil					
Direction of rotation		Same as motor					
Weight (kg)		4.9 kg					
Max. allowable housing temperature T (°C)		90 °C					

Bearings

Bearing service life depends mostly on output speed and axial load. Other factors, such as lubricant type, normally occurring impurities in the lubricant, operating temperature, etc. have also been taken into account. For the following chart, axial load is assumed to be in the middle of the output shaft. Contact our engineering team with your specific application..

Permitted shaft loads

Based on nominal bearing lifetime (L_{nh} as per ISO 281)

	Maximum Value	10000 hour	20000 hour	30000 hour	40000 hour
F _{2R} (N) Allowable radial force (Applied to the middle of the output shaft and n ₂ =100 rpm)	4550	4450	3700	3300	3000
F _{2A} (N) Allowable axial force n ₂ =100rpm (For both push and pull)	8000	7000	6000	5400	4550
F _{2R} = F _{2A} (N) simultaneously. For other complex cases, please inquire.	4550	3600	2800	2500	2250

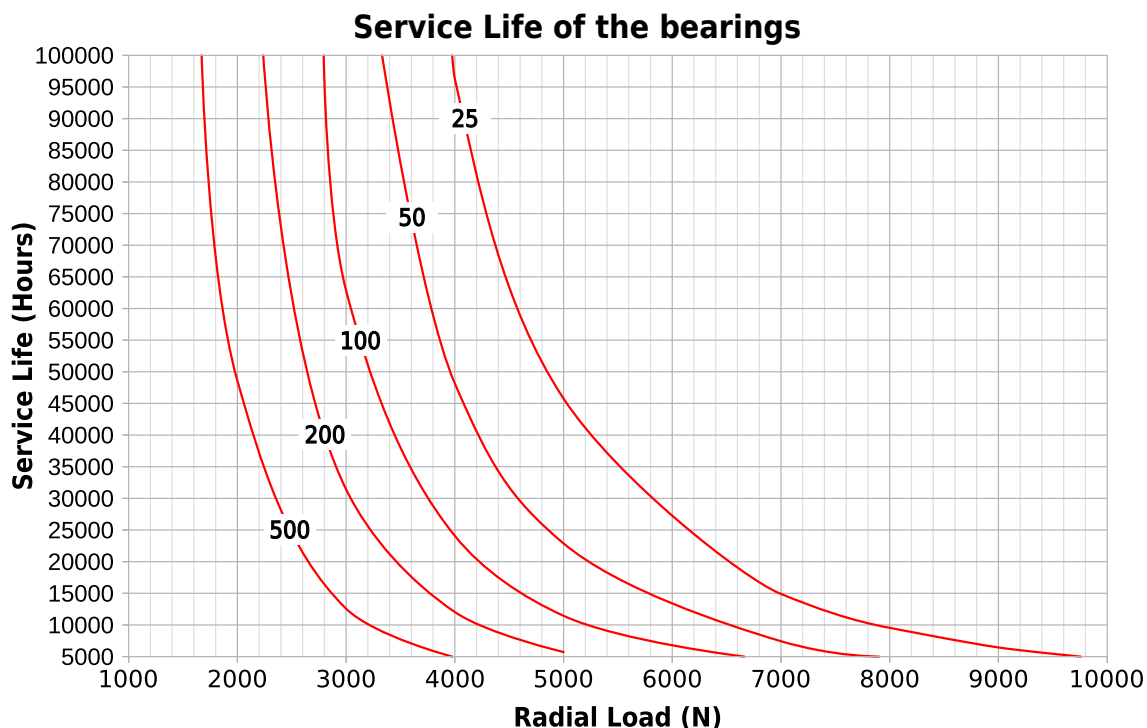

Bearing Service Life depending on radial load (N) and output speed (rpm)
Standard calculation as per DIN ISO 281

Dimensiones

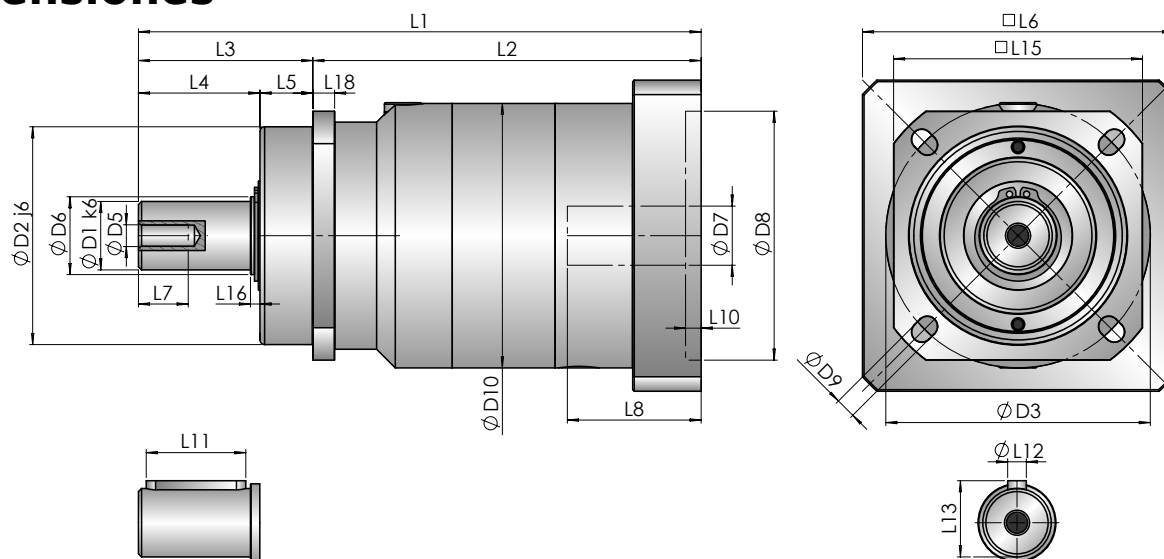

			SGS-080-M1	SGS-080-M2
D ₁	Output shaft diameter		22	22
D ₂	Pilot flange diameter		70	70
D ₃	Output flange fixing hole P.C.D.		85	85
D ₅	DIN 332 hole diameter		M8	M8
D ₆	Output shaft root diameter		25	25
D ₇	Input shaft diameter	min	9	9
D ₇	Input shaft diameter	max	24	24
D ₈	Input pilot flange diameter	min	50	50
D ₈	Input pilot flange diameter	max	110	110
D ₉	Output flange fixing hole diameter		6.5	6.5
D ₁₀	Housing diameter		85	85
L ₁	Total length	min	179	203
L ₁	Total length	max	190	214
L ₂	Housing length	min	123	147
L ₂	Housing length	max	134	158
L ₃	Length from the output flange		56	56
L ₄	Output shaft length		39	39
L ₅	Pilot diameter width		17	17
L ₆	Input flange side	min	85	85
L ₆	Input flange side	max	120	120
L ₇	DIN 332 hole thread depth		16	16
L ₈	Input shaft length	min	45	45
L ₈	Input shaft length	max	56	56
L ₁₀	Input pilot flange height	min	3.5	3.5
L ₁₀	Input pilot flange height	max	10	10
L ₁₁	Key length		32	32
L ₁₂	Key width		6	6
L ₁₃	Height over shaft		24.5	24.5
L ₁₅	Output flange side		80	80
L ₁₆	Output shaft root height		3	3
L ₁₈	Output flange thickness		7	7

All dimensions are in mm. Dimensions suitable for most motor models. For outliers, please inquire.
All values subject to change due to technical improvements without further notice..

Accessories

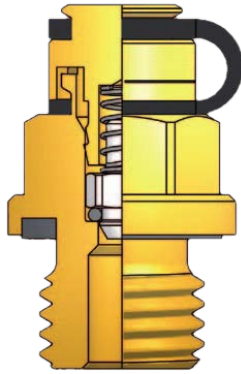

Vent Plugs

VP-G vent plugs use state of the art technology in pressure relief systems for gearboxes. A stainless steel spring lets the relief valve release generated gases while blocking ingress of contaminants.

VP-G plugs are most often installed for gearboxes that will either work under S1 continuous duty conditions, or whose duty cycle requires it. They are factory installed at the right location for the gearbox's correct operation. A rubber gasket seals the plug during transportation to prevent oil leakage.